

Plan View

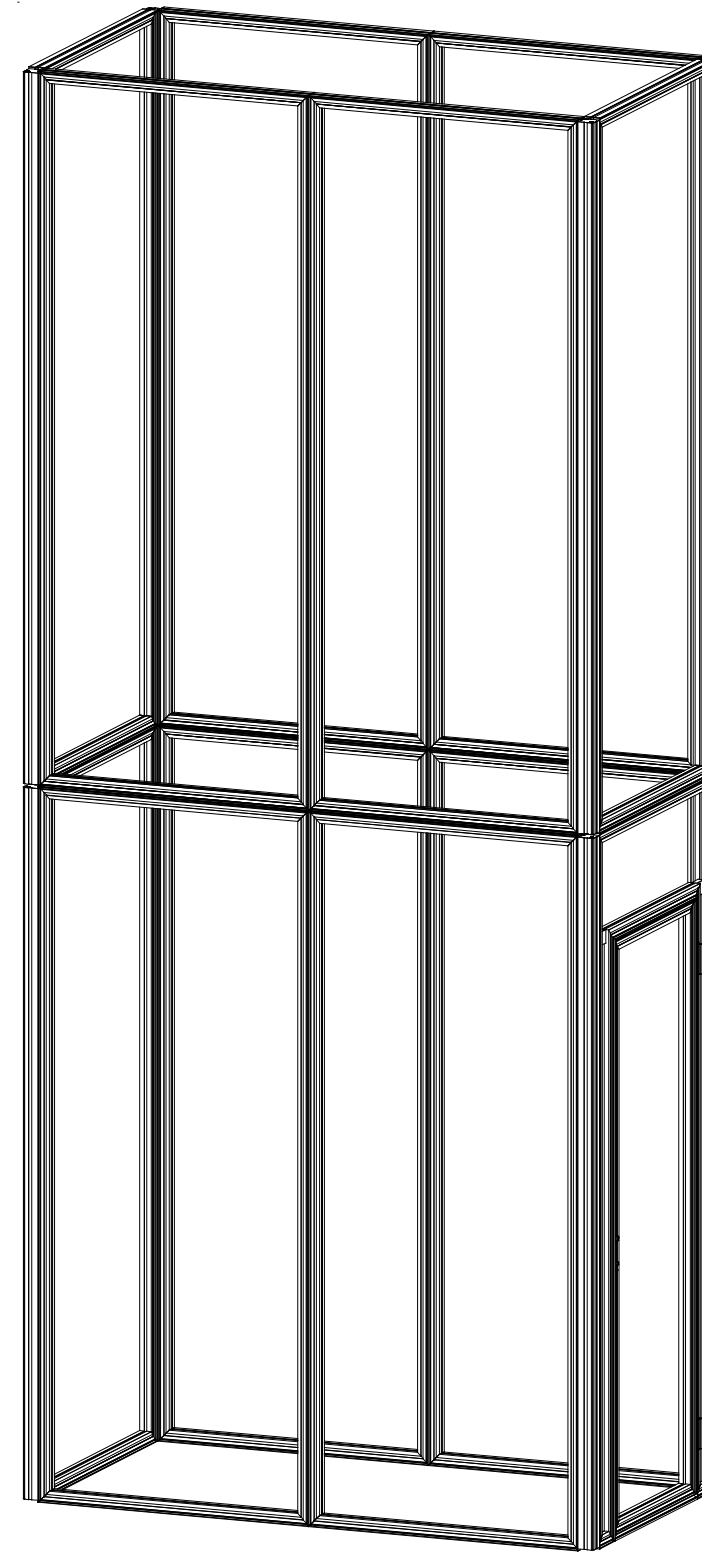

# SETUP INSTRUCTIONS

## General Setup Instructions

- Read entire setup instruction manual prior to unpacking parts and pieces.
- The setup instructions are created specifically for this configuration.
- Setup instructions are laid out sequentially in steps, including exploded views with detailed explanation for assembly.

## Cleaning & Packing

- For Cleaning Metal, Plex, & Laminate Parts: Use a **MILD NON-ABRASIVE** cleanser and soft cloth/paper towel to clean all surfaces.
- Keep exhibit components away from heat and prolonged sun exposure. **Heat and UV exposure will warp and fade components.**
- Retain all provided Packing Materials. All provided packing materials are for ease of repacking & component protection.

## Disassembly

- For loss prevention, tighten all set screws and locks during disassembly.

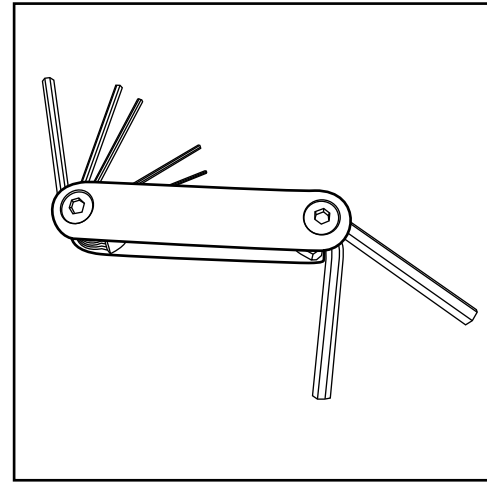

Hex Tool - Essential for Assembly

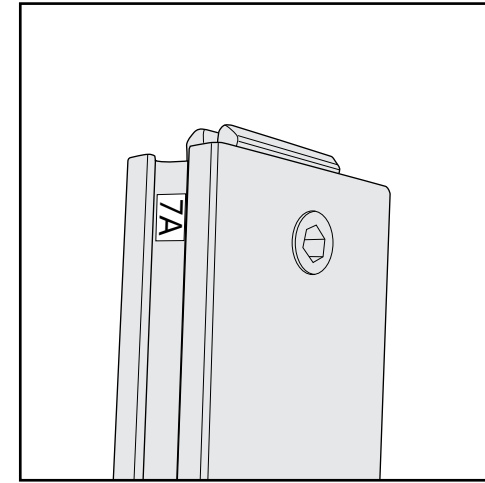

Part Identification - Numbering

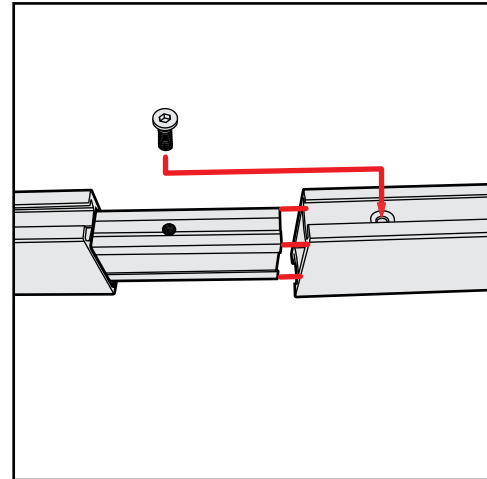

Spline Connection

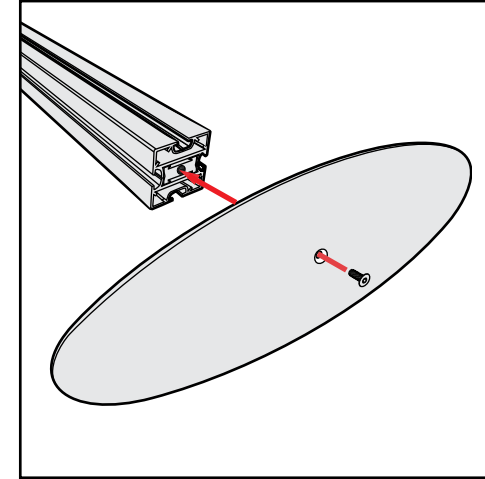

Base Plate & Extrusion Connection

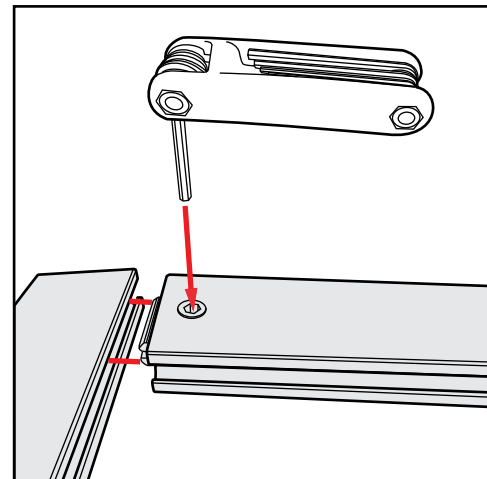

Extrusion & Lock Connection

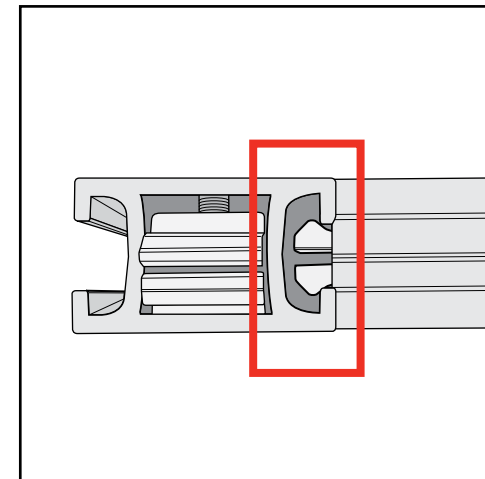

Engaged Lock



# WARNING



DO NOT USE POWER TOOLS



LADDERS OR LIFTS  
MAY BE REQUIRED



ALL CONNECTIONS MUST  
BE TIGHTLY SECURED

## Side-by-Side Assembly

- 1) Frames: Place frames side-by-side with one higher than the other, then slide panel down to lock panels securely together.
- 2) Corner Connectors: Repeat Step 1 for installing corner connectors to frames.

## Side-by-Side Disassembly

- 1) Pull pin lock outwards to disengage.
- 2) Pull frames upward and apart at the same time to detach.

Assembly

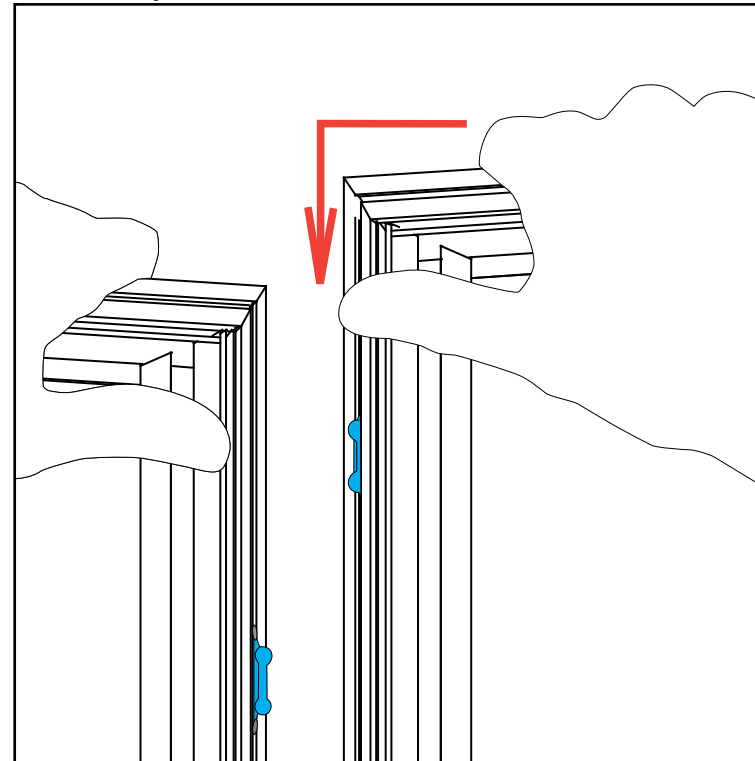

Assembly Cont'd

Push pin lock into hole of connecting frame.  
Note: Block of pin lock will secure in groove.

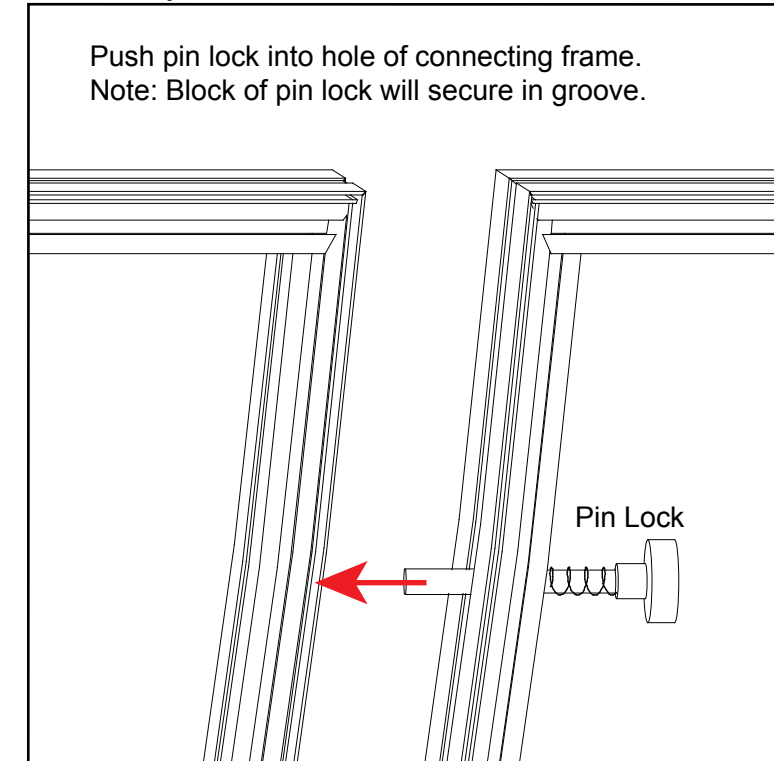

Corner Connector

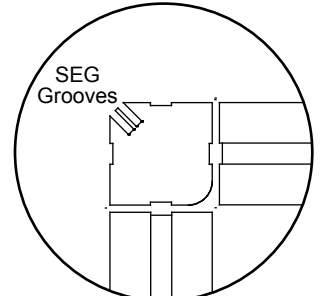

Top View  
Note: Orientation of Corner Connector may change.

## Stacking Assembly

- 1) Place one horizontal frame on top of the other, lining up the center grooves.
- 2) Turn stacking lock clockwise to tighten into place. Repeat for each lock.

## Stacking Disassembly

- 1) Turn the stacking lock counter-clockwise to loosen.
- 2) The whole spring on the stacking lock should be in view to release each frame. The disengaged spring should release the stacking lock. If not, keep turning the stacking lock until it disengages.

Stacking

Push stacking lock into the slot of the upper frame, then spin the cap to tighten the lock.

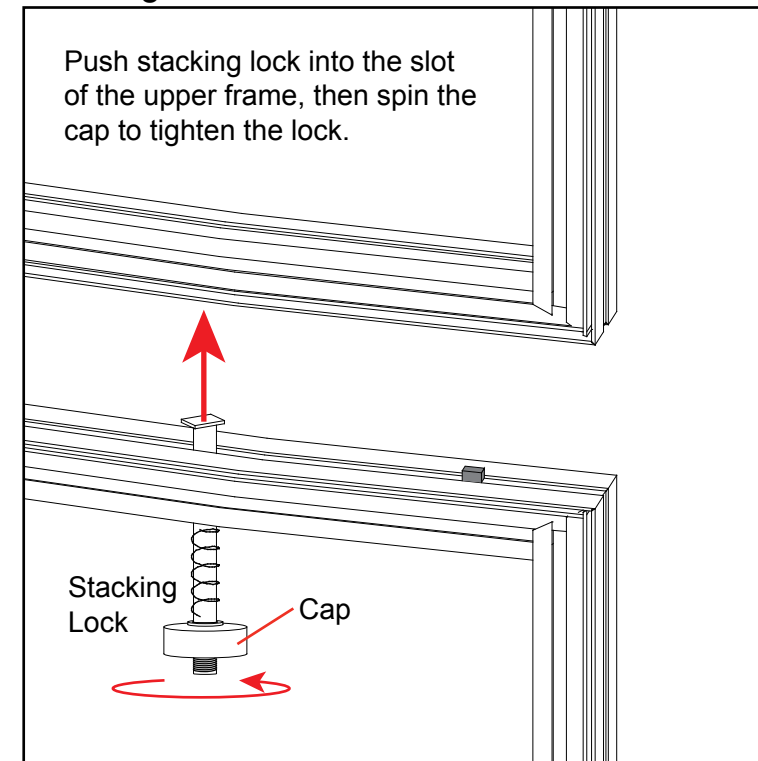

Unstacking

Disengage the stacking lock by spinning the cap counter clockwise and pulling down.

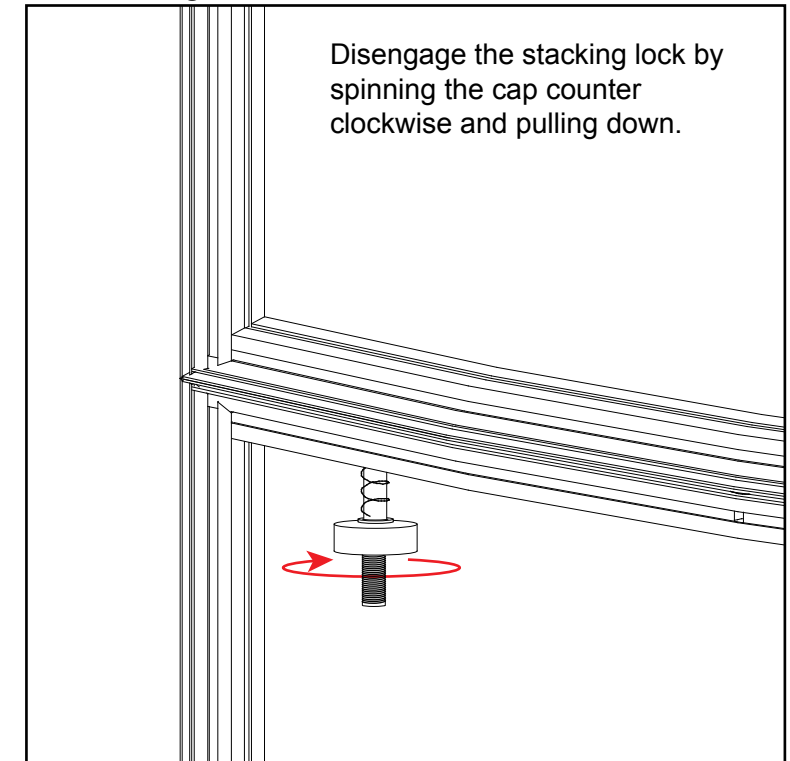

# SEG Graphic Installation *in 3 Steps*

*The Perfect Fit*

## STEP 1: Attach Corners

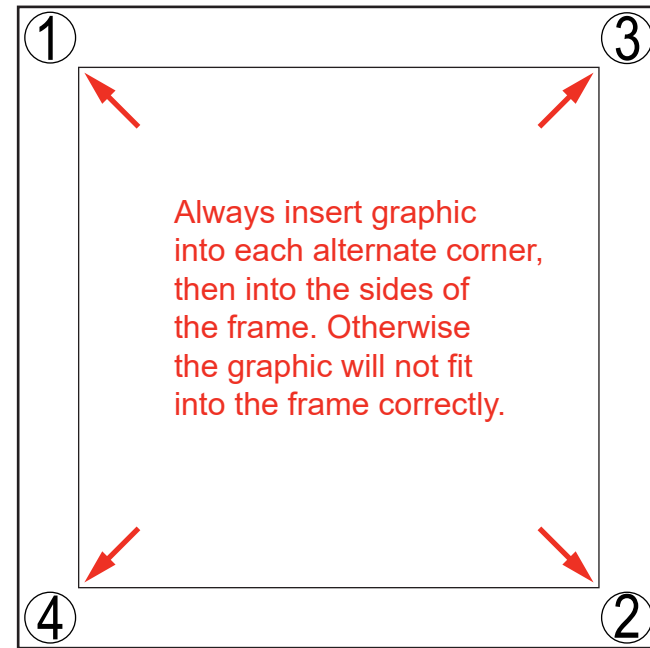

## STEP 2: Attach Middle

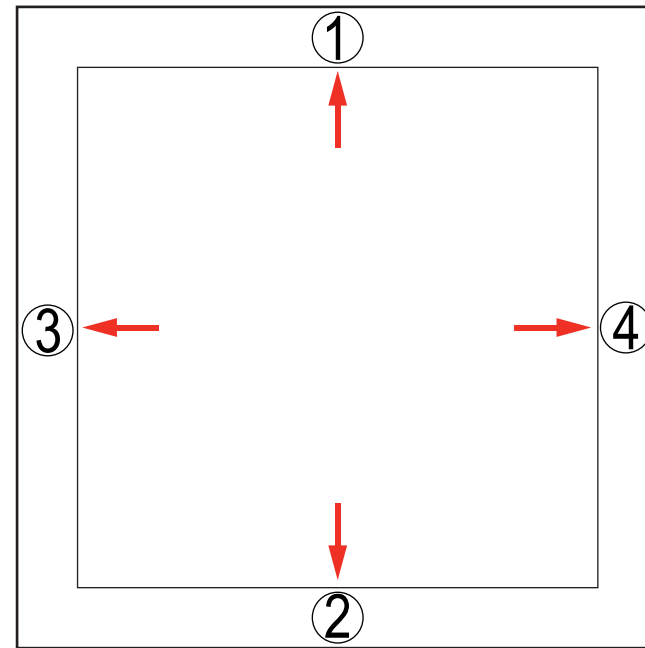

## STEP 3: Attach Sides

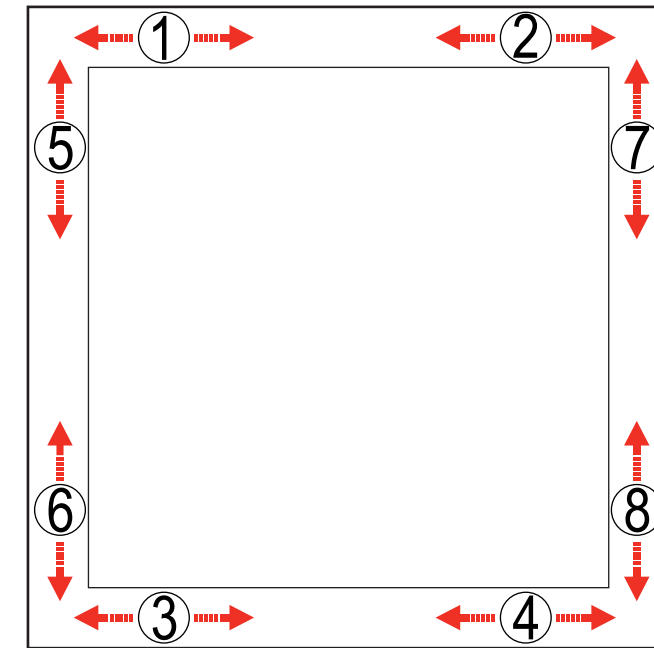

Insert narrow side of silicone welt into the channel at corner 1, with fabric to the outside.

Repeat for opposite corner 2, then corner 3, then corner 4.

Once corners are attached, press the middle of edge 1 into the channel. Then press middle of edge 2 into the channel on opposite side.

Repeat with edge 3 & 4.

Once the middle of sides are attached, fully press the silicone welt into the channel, between center and corner at location 1. Repeat the process between center and corner at location 2.

Do the same for welt on opposite side, at locations 3 & 4. Then repeat for locations 5 & 6 and 7 & 8.

Once the welt is fully inserted on all sides, smooth out edges as needed for a perfect fit.



To remove the graphic from the frame, locate the fabric **pull tab**. Gently pull on the tab to remove the graphic.

Install video:



CRATE PACKING

Item	Qty.	Description
1	1	38"w x 95"h Lower Gravitee Frame
2	1	94.5"h Lower Gravitee Corner Post w/ caps
3	1	38"w x 95"h Lower Gravitee Frame
4	1	38"w x 95"h Lower Gravitee Frame
5	1	94.5"h Lower Gravitee Corner Post w/ caps
6	1	38"w x 95"h Lower Gravitee Frame w/ Door
7	1	94.5"h Lower Gravitee Corner Post w/ caps
8	1	38"w x 95"h Lower Gravitee Frame
9	1	38"w x 95"h Lower Gravitee Frame
10	1	94.5"h Lower Gravitee Corner Post w/ caps

Steps:

Refer to the Gravitee Assembly general information page.

- 1) Assemble Gravitee panels & posts [1] through [10] in numerical order as shown.

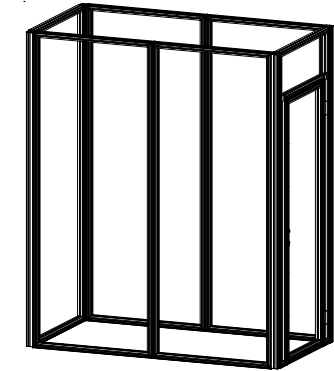

When assembled

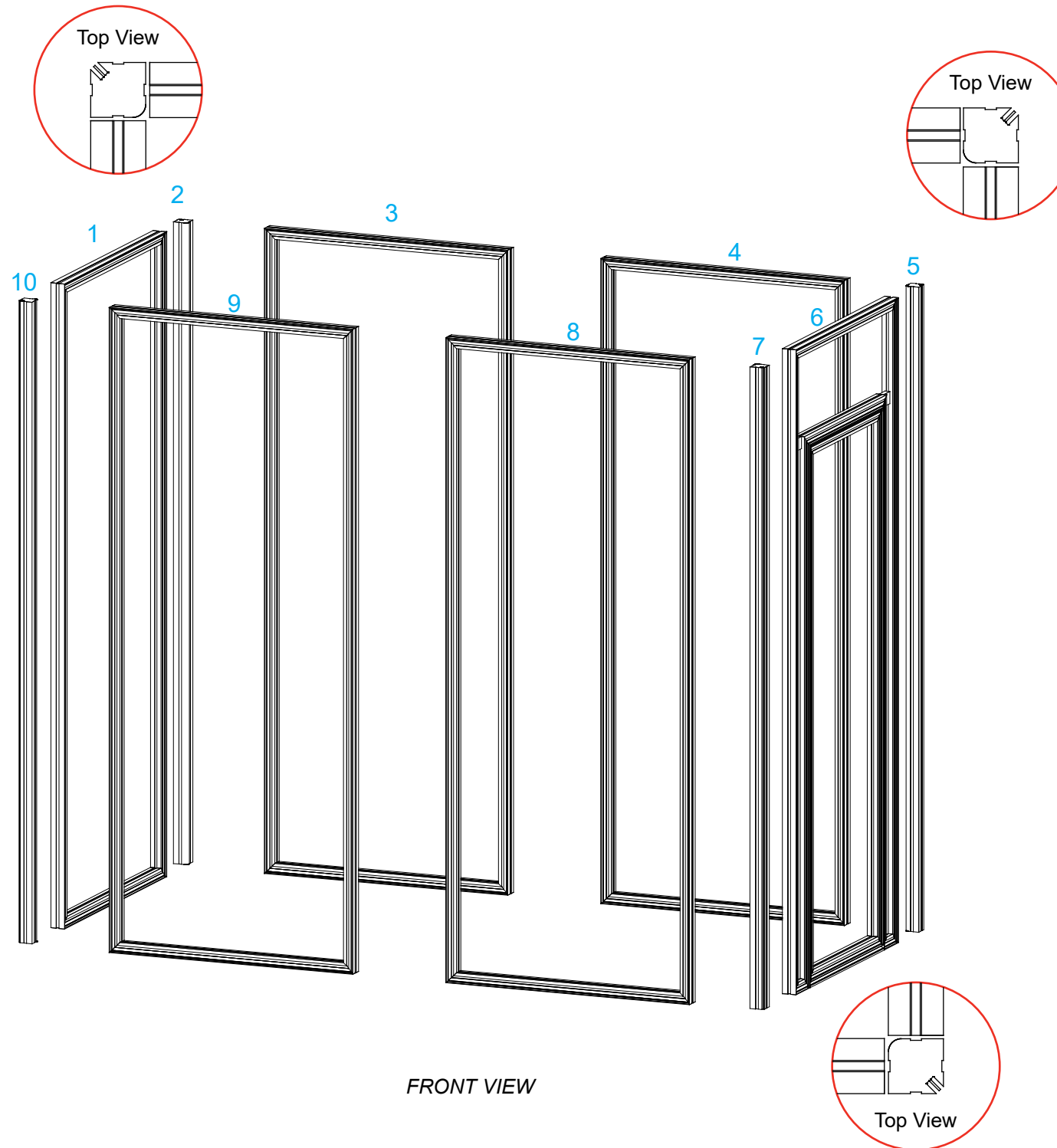

FRONT VIEW

Item	Qty.	Description
1	1	38" w x 95" h Upper Gravitee Frame
2	1	94.5" h Upper Gravitee Corner Post w/ caps
3	1	38" w x 95" h Upper Gravitee Frame
4	1	38" w x 95" h Upper Gravitee Frame
5	1	94.5" h Upper Gravitee Corner Post w/ caps
6	1	38" w x 95" h Upper Gravitee Frame w/ Door
7	1	94.5" h Upper Gravitee Corner Post w/ caps
8	1	38" w x 95" h Upper Gravitee Frame
9	1	38" w x 95" h Upper Gravitee Frame
10	1	94.5" h Upper Gravitee Corner Post w/ caps

Steps:

Refer to the Gravitee Assembly general information page.

- 1) Assemble Gravitee panels & posts [1] through [10] in numerical order, while attaching to lower panels.

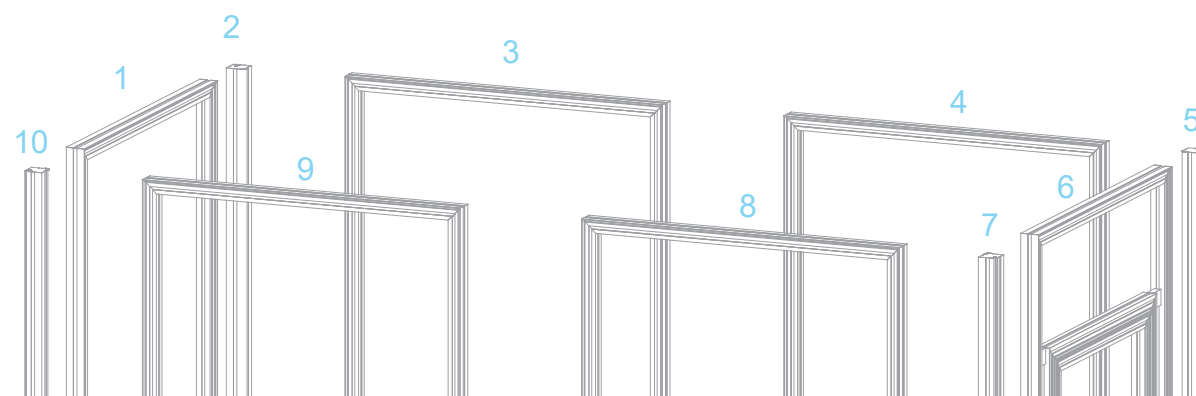
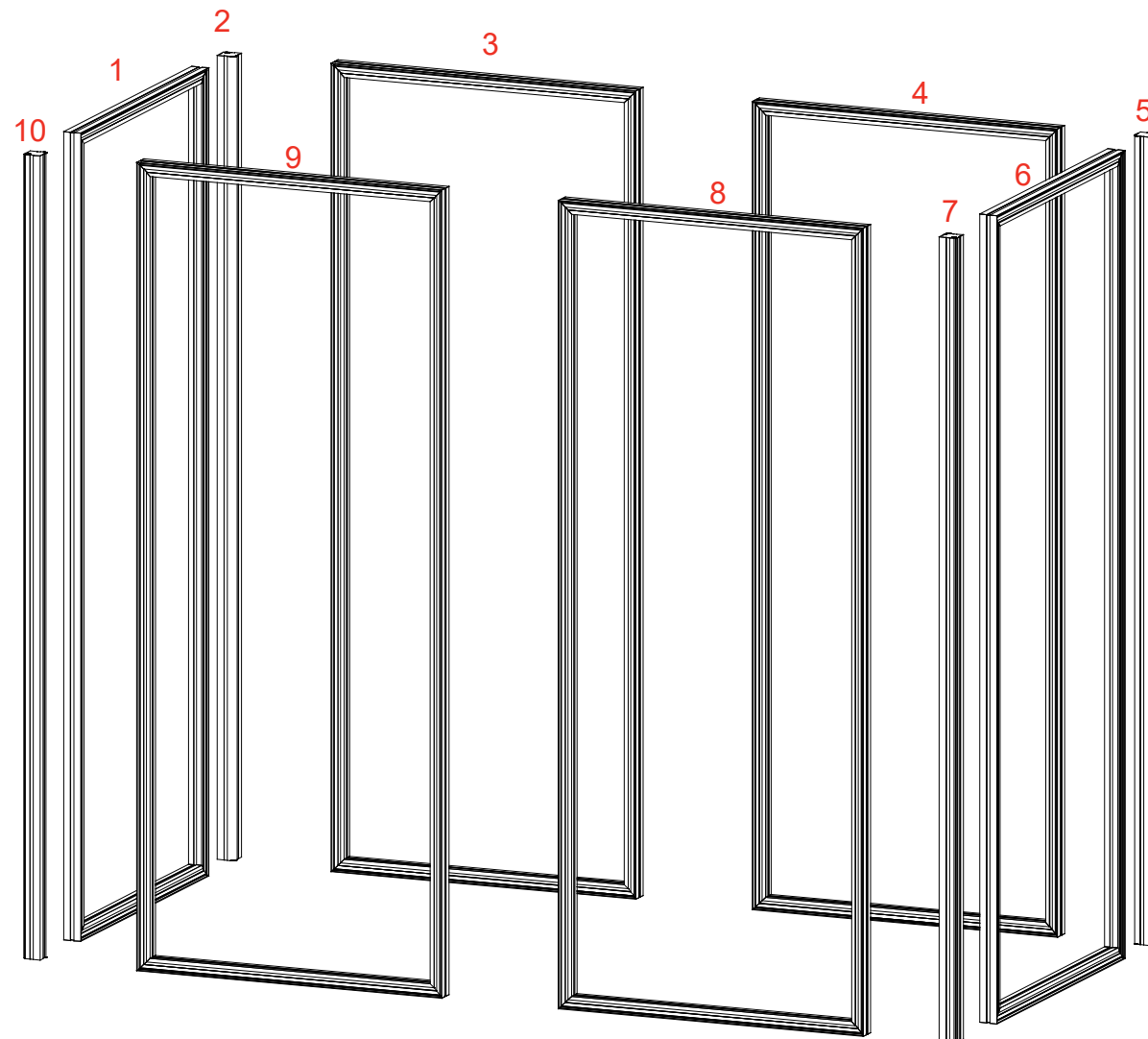

When assembled

## SEG Graphic Installation

### STEP 1: Attach Corners

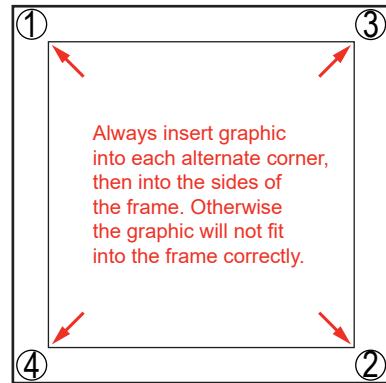

Insert narrow side of silicone welt into the channel at corner 1, with fabric to the outside.

Repeat for opposite corner 2, then corner 3, then corner 4.



### STEP 2: Attach Middle

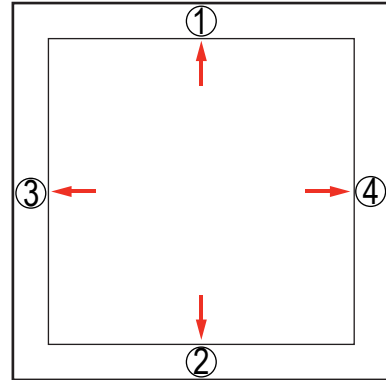

Once corners are attached, press the middle of edge 1 into the channel. Then press middle of edge 2 into the channel on opposite side.

Repeat with edge 3 & 4.

Once the middle of sides are attached, fully press the silicone welt into the channel, between center and corner at location 1. Repeat the process between center and corner at location 2.

### STEP 3: Attach Sides

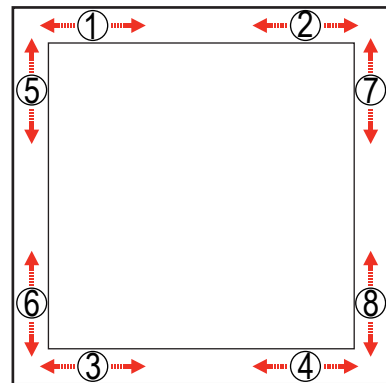

Do the same for welt on opposite side, at locations 3 & 4. Then repeat for locations 5 & 6 and 7 & 8.



Steps:

Refer to the SEG Installation general information page.

1) Apply SEG graphics as shown.

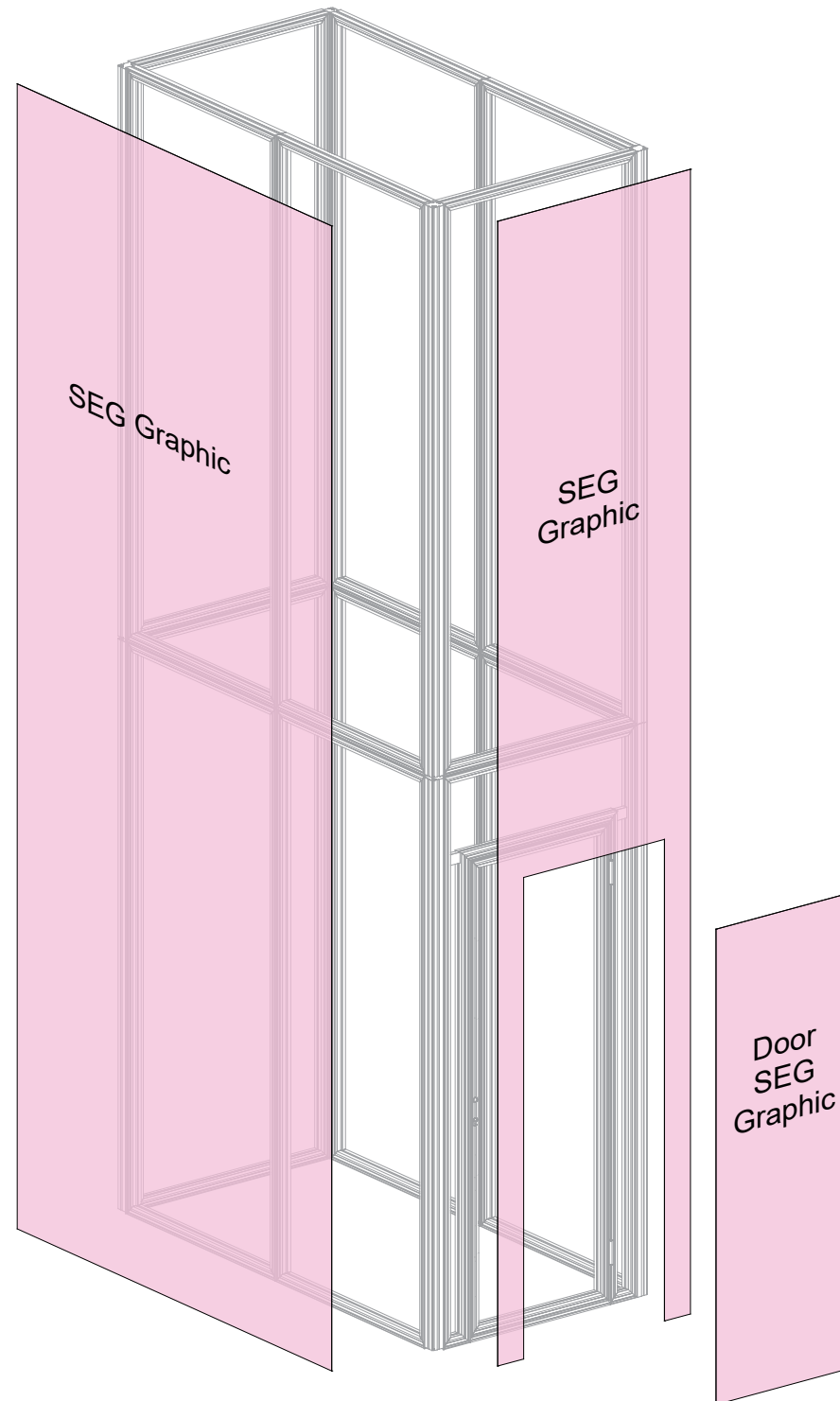

FRONT VIEW

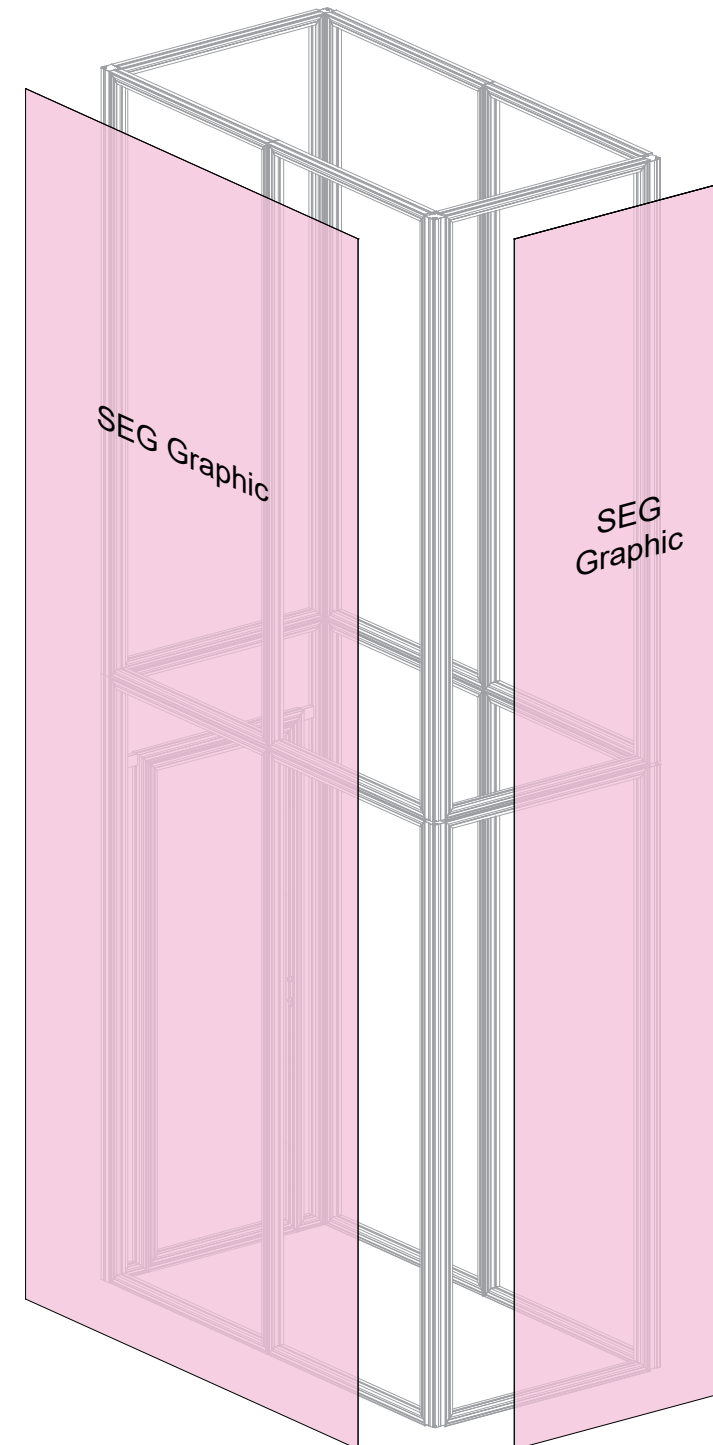

BACK VIEW